

# KBB

## FIRE VALVE

- Non-Electric Safety Valve
- Manual Reset
- Manual On/Off for Appliance Servicing
- Sensor System Fails Safe if Broken
- Two Alternative Temperature Settings
- Remote Sensing Up To 20m (66ft)
- Conforms To BS 5410 Part 1
- Approved To OFS E101

### Application

The KBB is designed as a fire safety shut-off valve for use on oil burning equipment. The valve is to be installed in the oil supply pipeline outside the building with the sensor mounted firmly inside the appliance above the burner. The capillary should then be run in a protected position without over-sharp bends particularly near the sensor and valve. The outline detail overleaf illustrates the relative positions of the valve and the sensor in a boiler compartment.

### Physical Description

The KBB is a compact valve of corrosion resistant, non-combustible construction and entirely mechanical in operation, requiring no power supply. The sensor is connected to the valve by a capillary, which cannot be detached. The reset button can be found at the base of the valve head and is pressed to reset the valve or if pulled will toggle the valve into the shut-off condition.



### Operation

The KBB is a quick acting thermally operated valve with a spring loaded trip mechanism and sealed temperature-sensing system consisting of a bellows, capillary tube and sensor phial. The valve will snap closed when the temperature at the sensor phial exceeds the set value. The valve will remain in the shut-off condition until the appropriate action has been taken to restore normal operating conditions and the reset button has been pressed.

The operation of the fire valve can be verified by using the KBT1000 test unit set to the appropriate temperature. This checks that the operation to shut-off the oil supply pipe takes place and enables a check to be made that the valve can be manually reset once the sensor phial temperature has reduced to normal operating level. The reset button must be pressed firmly to ensure the valve is positively latched in the open position.

The valve can also be shut-off manually by pulling the reset button.

## Technical Specification

Materials		Nominal Shut-down Temperatures	
Valve body and head	Brass	Oil supply pipe at atmospheric pressure	
Sensor phial and capillary	Copper	KBB/C/65	65°C
Valve seal	Nitrile Elastomer	KBB/C/90	90°C
Oil Supply Pipe Connections		Oil supply pipe at maximum pressure (10psi)	
1/4" BSP internal taper thread.		KBB/C/65	71°C
Spanner flats at connections 19mm (3/4")		KBB/C/90	95°C
Capillary Tube		Weight (approx.)	
1.5m (5ft), 3m(10ft) & 6m(20ft) using a 124mm long sensor		With 1.5m capillary	
9m(30ft), 12m(39ft), 16m(53ft) and 20m(66ft) using a 174mm long sensor		340g	
Nominal Fuel Flow Rate			
Kerosene	56 litres/hour at 1 meter head		
	85 litres/hour at 2 meters head		
Diesel	50 litres/hour at 1 meter head		
OFTEC Certificate Numbers			
KBB/C/65		0936 120205	
KBB/C/90		0936 030306	
Valve Seat			
6.4mm (1/4") diameter			

## Outline Details

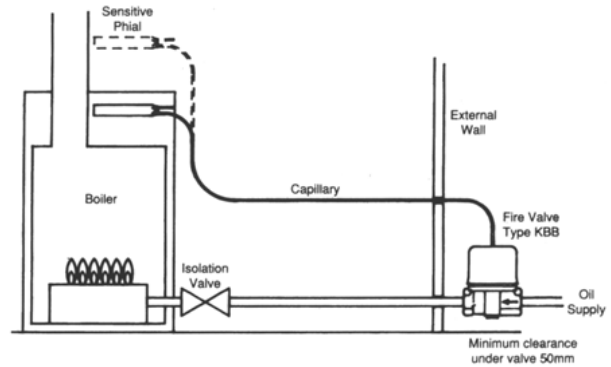
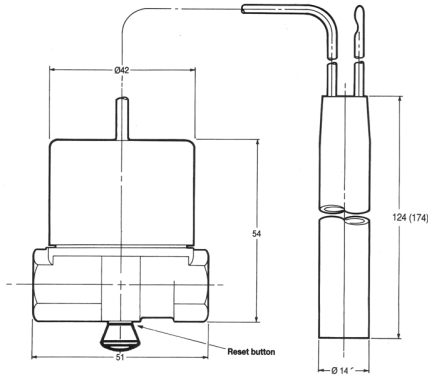

### Ordering Information

Temperature		Capillary Length	
65°C	65	1.5m (5ft)	
90°C	90	3m (10ft)	
		6m (20ft)	
		9m (30ft)	
		12m (39ft)	
		16m (53ft)	
		20m (66ft)	

KBB/C/ xx/xx

KBB/C/90 also available in a 2m length

### Distributed by:



## TEDDINGTON APPLIANCE CONTROLS LTD

Part of the **TEDDINGTON GROUP**  
 Holmush · St. Austell · Cornwall · United Kingdom · PL25 3HG  
 Tel: +44 (0) 1726 222505 · Fax: +44 (0) 1726 222502  
 www.tedcon.com · info@tedcon.com



FM 1790